



ÉQUERRES DE CHAISES à BOUTS RONDS

DESSCRIPTIF



Équerres de chaises à bouts ronds en acier zingué blanc.

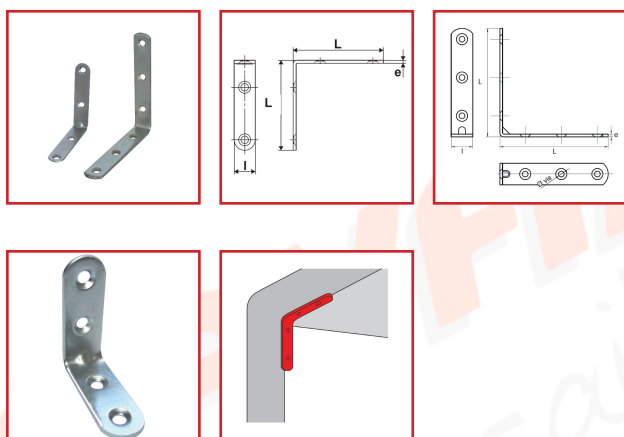

DETAILS

En acier zingué blanc.

Code	Longueur	Largeur	Epaisseur	Caractéristiques
445008	30 x 30 mm	14 mm	2 mm	4 vis 4,2 F
445010	40 x 40 mm	14 mm	2 mm	4 vis 4,2 F
445012	50 x 50 mm	14 mm	2 mm	4 vis 4,2 F
445014	60 x 60 mm	14 mm	2 mm	4 vis 4,2 F
445016	70 x 70 mm	18 mm	3 mm	Avec renfort - 4 vis 4,2 F
445018	80 x 80 mm	18 mm	3 mm	Avec renfort - 4 vis 4,2 F
445020	100 x 100 mm	18 mm	3 mm	6 vis 4,2 F

Fiche produit

Le 08/04/2026

SAVFIMA
Quincaillerie



445022	120 x 120 mm	18 mm	3 mm	6 vis 4,2 F
--------	--------------	-------	------	-------------

SAVFIMA
Quincaillerie

